



A28 Series Two-Stage Temperature Controls with NEMA 1 Enclosure

Application

These two-stage controls are designed to cover a broad range of general purpose operating temperature control applications in the refrigeration, air conditioning and heating fields.

Two SPDT switches permit independent control circuits. Each switch may be wired for "open high" or "close high" action, as required. Models are available with close differential on each switch. A jumper across the "common" terminals is supplied as a standard feature.

Models are available for fixed or adjustable between stage differential.

All Series A28 temperature controls are designed for use only as operating controls. Where an operating control failure would result in personal injury and/or loss of property, it is the responsibility of the installer to add devices (safety, limit controls) or systems (alarm, supervisory systems) that protect against, or warn of, control failure.



Fig. 1 – Exterior of the A28. Knob range adjustment is shown.

Specifications

Type Number	A28AA	Two SPDT Switches, Standard Differential
	A28AJ	Two SPDT Switches, Close Differential
Conduit Opening		7/8" (22 mm) Dia. Hole for 1/2" Conduit
Contact Action		Red to Yellow Closes on Temperature Rise Red to Blue Opens on Temperature Rise
Switch		SPDT, Snap-Acting Contacts in Dust Protected Enclosure
Differential	Each Switch	Fixed
	Between Stages	Adjustable or Fixed, As Specified
Enclosure	Case	0.062" (1.6 mm) Cold Rolled Steel
	Cover	0.025" (0.6 mm) Cold Rolled Steel
Finish		Gray Baked Enamel
Shipping Weight	Individual Pack	1.1 lb (0.5 kg)
	Overpack of 50 Units	56 lb (25 kg)

Features

- "Repeat" accuracy which is unaffected by barometric pressure and cross ambient temperature problems.
- Dependable single-pole, double-throw snap acting contacts in dust protected enclosure.
- Special close differential models available for critical requirements.

Range and Bulb Specifications

Adjustable Range (1) F (°C)	Differential F (°C)			Maximum Bulb Temperature (2) F (°C)	Bulb Size in (mm)	Bulb Style (3)
	Each Switch, Fixed		Between Stages			
	Standard	Close	Adjustable or Fixed			
-30 to +50 (-35 to +10)	5 (2.8)	2.5 (1.4)	2 to 7 as Specified (1.1 to 3.9)	140 (60)	.375 x 4 (9.5 x 102)	1 or 4
20 to 80 (-7 to +28)	3.5 (1.9)	2 (1.1)	2 to 7 as Specified (1.1 to 3.9)	140 (60)	.375 x 5 (9.5 x 127)	1 or 4
40 to 90 (5 to 30)	3 (1.7)	1.5 (0.8)	2 to 7 as Specified (1.1 to 3.9)	140 (60)	.375 x 6 (9.5 x 152)	1 or 4
30 to 110 (0 to 43)	3.5 (1.9)	2 (1.1)	2 to 7 as Specified (1.1 to 3.9)	140 (60)	.094 x 144 (2.4 x 3658)	9

(1) Other available ranges on quantity orders are -20 to +60°F (-29 to +16°C), -10 to +70°F (-23 to +21°C), 40 to 120°F (5 to 49°C), 50 to 200°F (10 to 90°C), 60 to 130°F (15 to 55°C), 60 to 140°F (15 to 60°C) and 100 to 240°F (40 to 120°C).

(2) Maximum bulb temperature which the element can withstand at infrequent intervals during the life of the control, such as shipping conditions. This is not the temperature which the control can withstand on repeat cycles.

(3) Style 4 is obtained by using Style 1 with support tube and adding FTG13A-600R packing nut assembly for 1/2" NPT tapping.

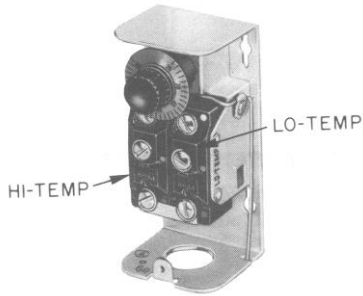

Fig. 2 -- Interior view showing high temperature (stage) and low temperature (stage) switches.

General Description

Controls are compact with nonadjustable differential on each switch. Knob range adjustment and visible scale are standard. Models are available with a knob for field convertible adjustment. These models are supplied with a snap-in plug in the cover for concealed screwdriver slot adjustment. Other features include a liquid-filled, copper sensing element which is unaffected by barometric pressure and cross-ambient temperature problems.

Controls may be supplied for immersion applications for use with a closed tank connector or with a bulb well assembly. A low cutout stop, which can be set in the field, is an integral part of the control.

Optional Constructions

Ambient Compensation

Available at extra cost.

Bulb

Coil bulb for low movement air application may be supplied. Also available is a 3/16 in. (4.76 mm) diameter by 22 in. (558 mm) long bulb for detecting the average temperature in air ducts.

Capillary

Capillary longer than 6 feet (1.8 m) available at extra cost. Capillary from 6 to 10 feet (1.8 to 3 m) in 2 foot (0.6 m) increments; over 10 feet (3 m) in 5 foot (1.5 m) increments.

Packing Nut

Part No. FTG 13A-600R is available for closed tank applications where the temperature does not fall below -35°F (-37°C) or exceed $+250^{\circ}\text{F}$ (121°C).

Maximum liquid pressure limit is 150 psig (1034 kPa). For applications where the temperature or liquid pressure exceeds these limits, specify Style 4 element with all metal packing nut as an integral part of the control.

Range Adjuster

Screwdriver slot with visible scale or screwdriver slot with internal scale and solid cover optional at no extra cost (quantity orders only). Models are available with knob, snap-in plug and remote bulb mounting clip for field convertible adjustment. This provides conversion to knob, concealed screwdriver slot or external screwdriver slot adjustment.

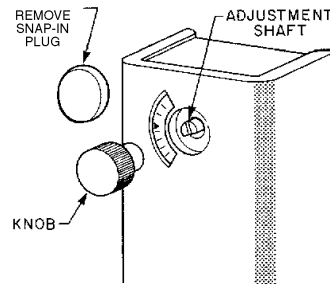

Fig. 3 -- Drawing showing snap-in plug removed and the knob in line to assemble. Press the knob onto the slotted shaft.

Electrical Ratings

A28AA — Standard Differential

Volts, AC	120	208	240	277
Full Load Amp	16.0	9.2	8.0	—
Locked Rotor Amp	96.0	55.2	48.0	—
Non-Inductive or Resistance Load Amp (Not Lamp Loads)	16.0	9.2	8.0	7.2

Pilot Duty — 125 VA, 24/277 VAC

NOTE: When used as a two circuit switch, the total connected load must not exceed 2000 VA.

A28AJ — Close Differential

Volts, AC	120	208	240	277
Full Load Amp	6.0	3.4	3.0	—
Locked Rotor Amp	36.0	20.4	18.0	—
Non-Inductive or Resistance Load Amp (Not Lamp Loads)	10.0	9.2	8.0	7.2

Pilot Duty — 125 VA, 24/277 VAC

NOTE: When used as a two circuit switch, the total connected load must not exceed 2000 VA.

Ordering Information

To order, specify:

1. Type number (see Type Number Selection).
2. Range required.

3. Between-stage differential (nonadjustable models only).
4. Capillary length, if other than 6 feet (1.8 m).
5. Packing nut assembly or bulb well, if required.

6. Specify type of range adjustment if other than knob adjustment.

Repairs and Replacement

Field repairs must not be made. For a replacement control, contact the nearest Johnson Controls wholesaler.

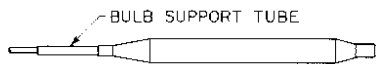

Fig. 4 – Style 1 swaged bulb with support tube for clamp-on or closed tank applications

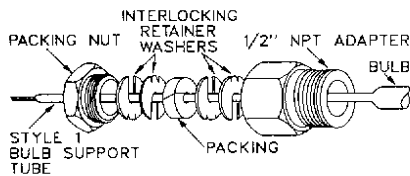

Fig. 5 – Part Number FTG13A-600R packing nut assembly. (Use with Style 1 bulb with support tube for direct immersion applications.)

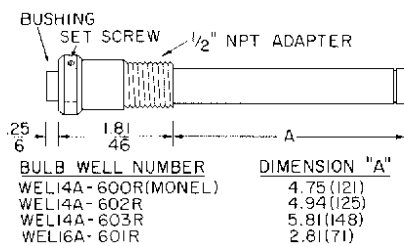

Fig. 6 – Bulb well for liquid immersion applications where a temperature bulb may be removed without draining tank.

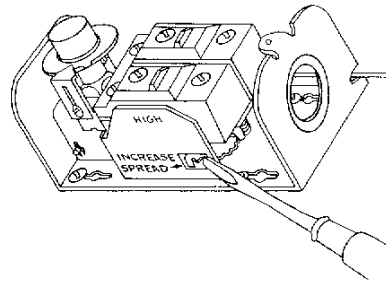

Fig. 7 – Between-stages differential can be increased by rotating adjusting cam counterclockwise as illustrated above.

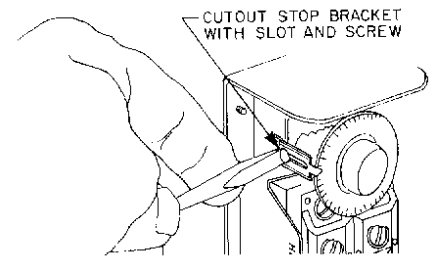

Fig. 8 – The controls have a screw type cutout stop. The stop screw must be loosened and moved to the stop setting desired. Tighten screw after setting is made.

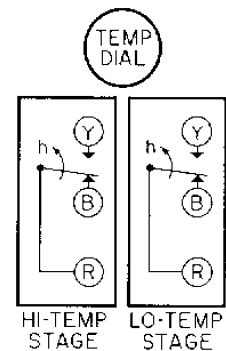
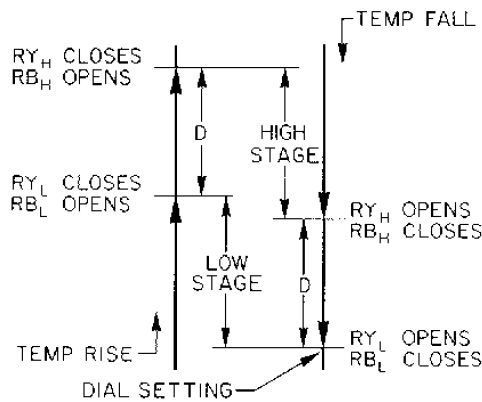

Fig. 9 – Switching action of the two-stage control is illustrated in the sketch above. RB_H, RY_H indicates HI-TEMP stage; RB_L, RY_L indicates LO-TEMP stage. "D" represents the differential between stages.

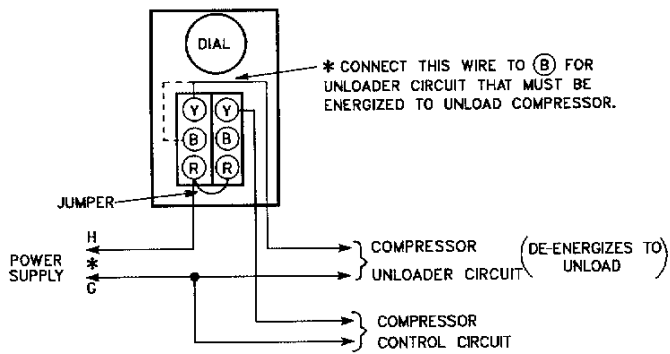
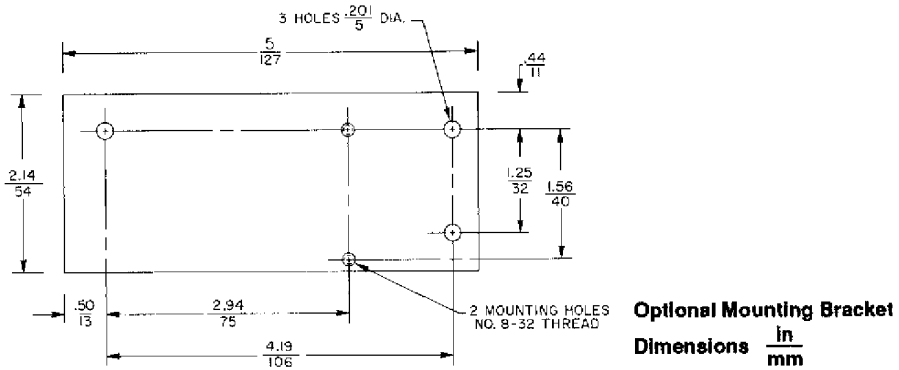
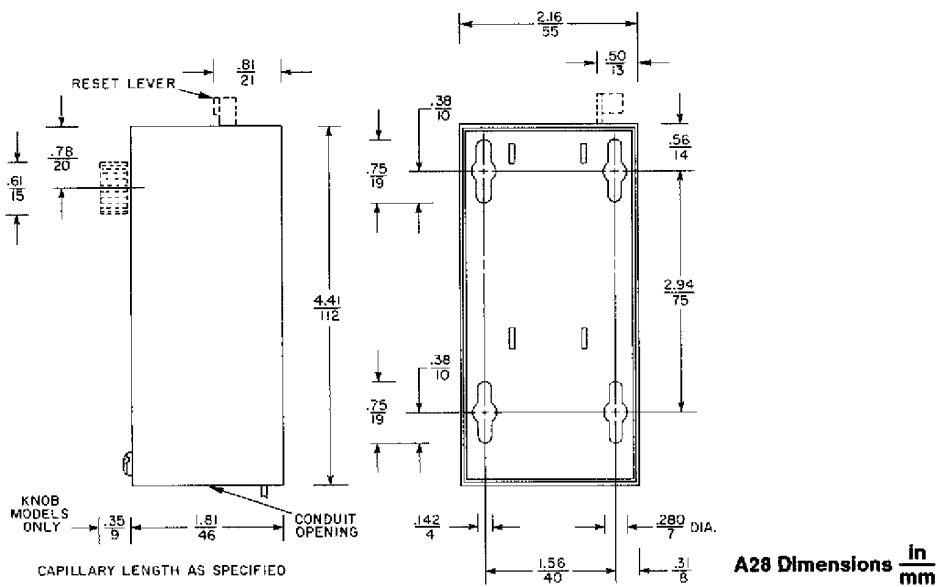

Fig. 10: Typical wiring diagram of a refrigeration compressor with single-stage unloader. Two compressor packages may be sequenced with the same circuit.



Performance specifications appearing herein are nominal and are subject to accepted manufacturing tolerances and application variables.

UL Guide No. XAPX
 File No. E6688
 CSA Class No. 4813 02
 File LR948